

OWNERS MANUAL

Thank you for purchasing an ALWAYS Bikes electric bicycle. We are proud to provide a quality product that will provide an un-paralleled ownership and riding experiences for years.

Please read and understand this Owners Manual fully before assembling and/or riding your eBike. If you have questions after reading this manual, please refer to ALWAYS Bikes Online Support.

eBliss Global, Inc. dba ALWAYS BIKES

<https://www.ALWAYSBikes.com/support>

eMail questions to support@alwaysbikes.com

Call Toll Free at 888-341-6450

The following document is a general owners manual.

The following links will help support your product, support, & information

1. Owners Manual
2. Assembly Guide
3. Model Specific Information
4. HMI/Display Manual



WARNINGS

Electric Bicycles are powered, street legal vehicles and demand full awareness while operating the eBike and knowledge of local driving laws.

While not all states require a drivers license to operate an eBike, eBliss Global dba Always Bikes STRONGLY recommends that only licensed drivers operate this eBike on public roads and paths.

This eBike is not to be sold to or operated by anyone under the age of 16.

Anyone operating or riding on an eBike MUST wear a helmet for safety & protection.

Any modification of this eBike, whether to hardware or software, can significantly jeopardize the safety of users, the reliability of the vehicle and voids all warranties.

Table of Contents

	Page
1. Using This Manual	4
2. General Safety	5
3. Important Safety Instructions	6
A. Risk of Fire or Electrical Shock	
B. Operating the eBike	
4. Operating and Maintaining Your eBike	7-9
A. Assembly and Fit	
B. Mandatory Equipment and Use Locations	
C. Changing Components or Attaching Accessories	
D. Safety Check Before Each Ride	
E. Electrical System	
F. Brakes	
G. Tires and Wheels	
H. Accessories, Straps and Hardware	
I. Suspension, Handlebar, Grips and Seat Adjustments	
J. Battery Charged, Secured and Unplugged	
K. Charger Safety Information	
L. Your Key & Battery Removal	
5. Instructions for Battery Charging	10
6. Operating eBike & HMI / Display Use	
7. HMI / Display Error Code	12-14
8. Warranty Policy	15-17
9. Key Technical Features	18-22
A. Wheel Safety	
B. Cam Action or Quick Release	
C. Thru Axle Bolt / Skewer	
D. Rear Wheel Installation and Removal	
E. eBike Fit and Adjustment	
F. Torque Settings	
10. Safety and Maintenance	23-30

1. Using This Manual

This manual contains details of the product, its equipment, and information on operation, maintenance, and other helpful tips for owners. Read it carefully and familiarize yourself with the eBike before using it to ensure safe use and to prevent accidents. This manual contains many warnings and cautions concerning the safe operation and consequences if proper setup, operation, and maintenance are not performed. All information in this manual should be carefully reviewed and if you have any questions, you should contact ALWAYS Bikes immediately.

The notes, warnings, and cautions contained within the manual and paragraphs are marked with a bold CAUTION or WARNING on the left side should be given special care. Users should also pay special attention to information marked in this manual beginning with

NOTICE.

Keep this manual, along with any other documents that were included with your bike, for future reference, however all content in this manual is subject to change or withdrawal without notice. Visit <https://www.ALWAYSBikes.com> for further information or to request the latest version of the manual. ALWAYS Bikes makes every effort to ensure the accuracy of its documentation and assumes no responsibility or liability if any errors or inaccuracies appear within.

Because it is impossible to anticipate every situation or condition that will occur while riding, this manual makes no representations about the safe use of bikes under all conditions. There are risks associated with the use of any bike that cannot be predicted or avoided and are the sole responsibility of the rider.

SAVE THESE INSTRUCTIONS

ALWAYS BIKES

Anytime, Anywhere, Outa'Here

are CLASS 3 eBikes

28mph motor assist and 20mph throttle assist

2. General Safety

Like any sport, bicycling involves risk of damage, injury, and death. By choosing to ride a bike, you assume the responsibility for that risk, so you need to know and practice the rules of safe and responsible riding and the proper use and maintenance of this bike. Proper use and maintenance of your bike reduces risk of damage, injury, and death.

Biking and controlled substances do not mix. Never operate a bike while under the influence of alcohol, drugs, or any substance or condition that could impair motor functions, judgement, or the ability to safely operate a bike or another vehicle.

This eBike is designed for use by persons 16 years old and older. Riders must have the physical condition, reaction time, and mental capability to ride safely and manage traffic, road conditions and sudden situations, as well as respect the laws governing electric bike use where they ride, regardless of age. If you have an impairment or disability such as a visual impairment, hearing impairment, physical impairment, cognitive/language impairment, a seizure disorder, or any other physical condition that could impact your ability to safely operate a vehicle, consult your physician before riding any bike. Ebike riding can be dangerous and can cause injury or death. Ride at your own confidence level and limitations. Know your bike and surrounding

Safety First

- Always wear an approved helmet when riding your eBike, and follow the helmet manufacturer's instructions for fit, use and care.
- Use all safety equipment. It's your responsibility to familiarize yourself with the laws of the areas where you ride, and to comply with all applicable laws.
- Do a safety check prior to every ride and ensure your wheels are correctly secure, aligned and tighten. Riding with an improperly secured wheel can cause the wheel to wobble or disengage from the eBike and cause serious injury or death. Check brakes for proper performance and secure and tighten all areas on the bike.
- **NOTE:** Suspension can change the way an eBike performs. Follow the suspension manufacturer's instructions for use, adjustment, and care.
- Riding Conditions- Prepare and know your conditions and roads planning to travel. There are many hazardous- such as traffic, road hazards, weather changes. Be CAREFUL and PREPARED. It can be dangerous to ride in wet, dusk, dawn, or night conditions. It can also be dangerous to ride on roads or terrain that changes in use, purpose or materials. Use CAUTION USE YOUR LIGHTS ALWAYS WEAR a HELMET. RIDE AT YOUR COMFORT and SAFETY
- Your Always Bike is not designed or warranted for EXTREME, STUNT, or COMPETITION. These riding styles can be dangerous and cause injury or death

A Note for Parents and Guardians

As a parent or guardian, you are responsible for the activities and safety of your child. This eBike is not designed for use by children under the age of 16. If you are carrying a passenger in a child safety seat, they should also be wearing a properly fitted and approved helmet.

CAUTION! ALWAYS Bikes is not liable for accidents, injuries or product malfunctions that result from any unauthorized changes, modifications or tampering with any part of original specifications or assembly.

3. Important Safety Instructions

A. Risk of Fire or Electric Shock

WARNING! When using this product, basic precautions should always be followed, including the following:

- **Read all the instructions before using the product.**
- To reduce the risk of injury, close supervision is necessary when the product is used near children.
- **Do not** put fingers or hands into the product.
- **Do not** use this product if the flexible power cord or output cable is frayed, has broken insulation, or any other signs of damage.
- This equipment is **not intended** to be used at ambient temperatures less than -0.4°F (-18°C) or above ambient temperatures of 104°F (40°C).
- The battery is intended to be charged when the ambient temperature is between 32°F (0°C) & 104°F (40°C). **Never** charge the battery when ambient temperatures are outside this range.

B. Using the eBike

WARNING! It is your responsibility to comply with all traffic-related laws and to use proper safety equipment. This includes wearing appropriate cycling attire and performing bike maintenance.

- Observe all local bicycle traffic laws and regulations.
- Observe regulations about bicycle lighting, riding on pavements/sidewalks, bike path and trail use, helmet laws, child laws relating to cycling, and special bicycle traffic laws. It is your responsibility to know and obey your local laws.
- When riding a bike, always wear a properly fitted helmet that covers the forehead and that has securely fastened chinstrap. Many locations require specific safety devices. It is your responsibility to familiarize yourself with the local laws, rules, and regulations where you ride and to comply with all applicable laws, including equipping yourself and your bike as the law requires.
- Before you ride your bike, always check to make sure everything is working properly and correctly aligned - brakes, handlebars/front wheel and seat.
- Be familiar with the controls of your bicycle, such as brakes, pedals and shifting etc.
- Keep all body parts, clothing and other objects away from the belt when pedaling. Failure to wear proper attire could lead to injuries.
- While riding, remember you are sharing the road or path with others. i.e. motorists, pedestrians and other cyclists.
- Always be a defensive rider. Always assume that others do not see you and be prepared for the unexpected. Always be aware of your surroundings.
- Ride in designated bike lanes when available and always ride in the direction of traffic.
- Acknowledge and stop at ALL stop signs and traffic lights.
- Look both ways at street intersections before continuing onward.
- Use official hand signals for turning and stopping.
- Do not weave through traffic or make unexpected moves or turns.
- Rules that govern the right-of-way for motorists apply to cyclists. A bicyclist should always be prepared to yield.
- Avoid riding in bad weather or when visibility is obscured, for examples dawn, dusk, or in the dark as such conditions increase the risk of accident.

4. Operating & Maintaining Your eBike

A. Assembly & Fit

- Correct assembly and fit are essential elements to ensure your bicycling safety, performance, and comfort.
- Even if you have the experience, skill, and tools to complete these essential steps before your first ride, ALWAYS Bikes recommends having a certified, reputable bike mechanic to check your work.
- **NOTICE:** If you do not have the experience, skill, and tools to complete assembly and fit, ALWAYS Bikes highly recommends having a certified, reputable bike mechanic complete these procedures as well as any future adjustments or tuning.
- **NOTICE:** A critical aspect of assembling your bike is securing the front wheel and checking the tightness of the rear wheel axle nuts. ALWAYS Bikes use bolted on, through axle or quick release front wheel mounting mechanism and the rear wheel is bolted on. These mechanisms may become loose or unsecured during shipment or over time. The torque and security of all wheel mounting hardware should be inspected upon arrival and on a regular basis. Both wheels need to be properly secured before operating your bike.

B. Mandatory Equipment & Use Locations

- Before riding, ensure you have all required and recommended safety equipment and are following all laws pertaining to the use of an electric bike in your region. For example, these laws may specify the need for mandatory equipment, use of hand signals, and where you can ride.

C. Changing Components or Attaching Accessories

- The use of non-original components or spare parts can jeopardize the safety of your eBike, void your warranty and, in some cases, cause your eBike to not conform with laws pertaining to your bike.

D. Safety Check Before Each Ride

- Always check the condition of your bike before you ride in addition to having regular maintenance performed. If you are unsure of how to conduct a complete check of the condition of your bike before every ride, you should consult a certified, reputable bike mechanic for assistance.
- **The replacement of original components or installation of third-party accessories or accessories not explicitly recommended for your bike model by ALWAYS Bikes is at your own risk. Using aftermarket accessories or components that have not been tested by ALWAYS Bikes for safety and compatibility may void your warranty, create an unsafe riding condition, damage property or your bike, or result in serious injury or death.**

Continued- 4. Operating & Maintaining Your eBike

E. Electrical System

- The electrical system powers several components of your eBike that control different operating functions and user preferences. It is critical that you familiarize yourself with all aspects of your eBike's electrical system and check to see if it is working correctly before every ride. The front and rear brake levers should be checked for correct operation prior to riding. The throttle should provide smooth acceleration while operating your eBike. If these or other aspects of your eBike are not working correctly, please discontinue the use of your eBike immediately and contact the ALWAYS Bikes Support team for assistance.

F. Brakes

- Ensure that the brakes and their system components are free from damage, properly secured and working correctly. When fully squeezed, both front and rear brake levers should not be touching the handlebar. If you find a problem, take your bike to a certified, reputable bike mechanic to have the brakes repaired.

G. Tires & Wheels

- Your wheels should always spin straight and must be repaired or replaced if they wobble side to side or up and down when spinning. If your wheels become untrue or spokes loosen, which can happen with normal use, we recommend that a certified, reputable bike mechanic perform all wheel tuning and tuning operations on your bike from ALWAYS Bikes. Do not attempt to true wheels or tighten spokes unless you have adequate knowledge, tools, and experience. Ensure the tires and inner tubes are in good working condition without any visual damage and have the correct amount of air pressure (as defined in the Specifications table of this manual). Always replace tires and inner tubes with punctures, cuts, or damage before you ride. Tires without the correct amount of air pressure can reduce performance, increase tire and component wear, and make riding your bike unsafe.

H. Accessories, Straps, & Hardware

- Ensure all hardware is secured and all approved accessories are properly attached per the specific component manufacturer's instructions. It is good practice to look over all hardware, straps, and accessories before each ride and if you do discover something wrong or something that you are not sure about, have it checked by a certified, reputable bike mechanic.

I. Suspension, Handlebar, Grips, & Seat Adjustments

- Ensure the handlebar and handlebar stem are properly aligned, fitted to the user, and secured to the recommended torque values. Handlebar grips should not move easily on the handlebar end. Loose, worn, or damaged handlebar grips should be replaced before you ride. The seat and seat post should be properly aligned, fitted for the rider's height, and the seat post quick release should be properly tightened, fully closed, and secured before riding.

Continued- 4. Operating & Maintaining Your eBike

J. Battery Charged, Secured, & Unplugged

- Ensure the battery is adequately charged and operates properly. Ensure the battery charger is unplugged from the outlet and battery and then stored in a safe location before you ride.

K. Charger Safety Information

- The charger should only be used indoors in a cool, dry, ventilated area on a flat, stable, hard surface.
- Avoid charger contact with liquids, dirt, debris or metal objects. DO NOT cover the charger while in use.
- Store and use the charger in a safe place away from children.
- Fully charging the battery before each use can help extend the life of the battery and reduces the chance of over-discharging.
- **WARNING! DO NOT** charge the battery with any chargers other than the one originally supplied by ALWAYS Bikes or a charger designed for use with your specific bike purchased directly from ALWAYS Bikes.
- **WARNING!** The charger works on 110/240V 50/60 Hz standard home AC power outlets and automatically detects and accounts for incoming voltage. DO NOT open the charger or modify voltage input.
- **WARNING! DO NOT** yank or pull on the cables of the charger. When unplugging carefully remove both the AC and DC cables by pulling on the plastic plugs directly, and not on the cables.
- The charger is expected to get relatively warm as it charges the battery. If the charger gets too hot to touch, you notice a strange smell, or any other indicator of overheating, discontinue using the charger and contact ALWAYS Bikes Support.

L. Your Key & Battery Removal

- Is used to unlock and remove the battery. Your key has a code stamped on it & a matching code on the cylinder. YOU DO NOT NEED the KEY to start your bike



1. Open the battery key.



2. Take out the battery –



3. After taking out the



4. Removed battery.

5. Instructions for Battery Charging

Charging Procedure

Follow these steps for charging your eBike battery from ALWAYS Bikes:

1. **Ensure eBike is OFF**
2. You can charge the battery on the bike or remove and charge
3. To CHARGE on the BIKE- Remove the rubber cover on the charging port.
4. TO CHARGE off the BIKE- Remove Battery using the key and latch
5. **Plug the charger into the battery' s charging port:** place the charger in a flat, secure place, and connect the DC output plug from the charger (round barrel connector) to the charging port on the side of the battery.
6. **Plug the charger into a power outlet:** Connect the charger input plug (110/220 -volt plug) to the power outlet. Charging should initiate and will be indicated by the LED charge status light on the charger illuminating as red light.
7. **Unplug the charger from the outlet, then the charging port:** Once fully charged, as indicated by one charging indicator light turning green, unplug the charger from the wall outlet first and then remove the charger output plug from the battery charging port.

Always charge your battery in temperatures between 32°F - 104°F (0°C - 40°C) and ensure the battery and charger are not damaged before initiating charge. If you notice anything unusual while charging, please discontinue charging and using the bike and contact ALWAYS Bikes Product Support for help.



1. Take out the battery charger.



2. Charger hole in on the left side of the frame and near the folde.



3. Plug the charger into power supply.



4. Red light shows the battery is charging, green light is full.



6. Operating eBike & HMI / Display Use

Turning on your eBike

1. Power On/Off. Hold down the button until screen becomes active.
2. Do not put any weight (feet, bags, etc) on the pedals during start-up. The system calibrates the torque sensor at this time.
3. **+** button to increase the pedal assist level - levels: 0-5
4. **-** button to decrease the pedal assist level - levels: 0-5



TRIP/PAS LEVELS

	Anytime	Outa'Here	Anywhere
5	28 mph	28 mph	23.5 mph
4	25	25	20
3	17	17	14
2	14	14	12
1	10	10	8
0	HUMAN POWERED- Walk Mode / Motor Assist up to 1.3 mph is available in TRIP 0		
<i>Throttle use will get you up to 20 mph</i>			

TRIP/PAS Info

- The Display is also referred to as HMI (Human Machine Interface)
- The Bafang system refers to PAS (Pedal Assist Setting) as TRIP- these are interchangeable
- TRIP/PAS helps will get you to the TOP Speed for each LEVEL
- Our system has 6 settings -Guide for speed by setting included

Continued- 7. HMI / Display Error Code

Bafang HMI Error Code Definitions: Model C221/C231

The display can show the errors of that may occur on your Always Bike. If an error is detected, the error code appears on the display and one of the following error codes will be displayed.

Note: Please read the description of the error code carefully. If you see the error code, restart the system first. If the problem is not resolved, please contact your dealer.

ERROR CODE	Description	Technical Support
04	The throttle has fault	<ol style="list-style-type: none">1. Check the connector and cable of the throttle are not damaged and correctly connected.2. Disconnect and reconnect the throttle, if still no function please change the throttle.
05	The throttle is not back in its correct position	Check the connector from the throttle is correctly connected. If this does not solve the problem, please change the throttle.
07	Overvoltage protection	<ol style="list-style-type: none">1. Remove and re-Insert the battery to see if it resolves the problem.2. Using the BESST tool update the controller.3. Change the battery to resolve the problem.
08	Error with the hall sensor signal inside the motor	<ol style="list-style-type: none">1. Check all connectors from the motor are correctly connected.2. If the problem still occurs, please change the motor.
09	Error with the Engine phase's	Please change the motor.
10	The temperature inside the engine has reached its maximum protection value	<ol style="list-style-type: none">1. Turn off the system and allow the eBike to cool down.2. If the problem still occurs, please change the motor.
11	The temperature sensor inside the motor has an error	Please change the motor.
12	Error with the current sensor in the controller	Please change the controller or contact your supplier.
13	Error with the temperature sensor inside of the battery	<ol style="list-style-type: none">1. Check all connectors from the battery are correctly connected to the motor.2. If the problem still occurs, please change the Battery.
14	The protection temperature inside the controller has reached its maximum protection value	<ol style="list-style-type: none">1. Allow the eBike to cool down and restart the system.2. If the problem still occurs, please change the controller or contact your supplier.
15	Error with the temperature sensor inside the controller	<ol style="list-style-type: none">1. Allow the eBike to cool down and restart the system.2. If the problem still occurs, Please change the controller or contact your supplier.
21	Speed sensor Error	<ol style="list-style-type: none">1. Restart the system2. Check that the magnet attached to the spoke is aligned with the speed sensor and that the distance is between 10 mm and 20 mm.3. Check that the speed sensor connector is connected correctly.4. Connect the eBike to BESST, to see if there is a signal from the speed sensor.5. Using the BESST Tool- update the controller to see if it resolves the problem.6. Change the speed sensor to see if this eliminates the problem. If the problem still occurs, please change the controller or contact your supplier.

Continued- 7. HMI / Display Error Code

Bafang HMI Error Code Definitions: Model C221/C231

The display can show the errors of that may occur on your Always Bike. If an error is detected, the error code appears on the display and one of the following error codes will be displayed.

Note: Please read the description of the error code carefully. If you see the error code, restart the system first. If the problem is not resolved, please contact your dealer.

ERROR CODE	Description	Technical Support
25	Torque signal Error	<ol style="list-style-type: none">1. Check that all connections are connected correctly.2. Please connect the eBike to the BESST system to see if torque can be read by the BESST tool.3. Using the BESST Tool update the controller to see if it resolves the problem, if not please change the torque sensor or contact your supplier.
26	Speed signal of the torque sensor has an error	<ol style="list-style-type: none">1. Check that all connections are connected correctly.2. Please connect the eBike to the BESST system to see if speed signal can be read by the BESST tool.3. Change the Display to see if the problem is solved.4. Using the BESST Tool update the controller to see if it resolves the problem, if not please change the torque sensor or contact your supplier.
27	Overcurrent from controller	Using the BESST tool update the controller. If the problem still occurs, please change the controller or contact your supplier.
30	Communication problem	<ol style="list-style-type: none">1. Check all connections on the eBike are correctly connected.2. Using the BESST Tool run a diagnostics test, to see if it can pinpoint the problem.3. Change the display to see if the problem is solved.4. Change the EB-BUS cable to see if it resolves the problem.5. Using the BESST tool, re-update the controller software. If the problem still occurs, please change the controller or contact your supplier.
33	Brake signal has an error (If brake sensors are fitted)	<ol style="list-style-type: none">1. Check all connectors are correctly connected on the brakes.2. Change the brakes to see if the problem is solved. If problem continues, Please change the controller or contact your supplier.
35	Detection circuit for 15V has an error	Using the BESST tool update the controller to see if this resolves the problem. If not, please change the controller or contact your supplier.
36	Detection circuit on the keypad has an error	Using the BESST tool update the controller to see if this resolves the problem. If not, please change the controller or contact your supplier.
37	WDT circuit is faulty	Using the BESST tool update the controller to see if this resolves the problem. If not, please change the controller or contact your supplier.
41	Total voltage from the battery is too high	Please change the battery.
42	Total voltage from the battery is too low	Please Charge the battery. If the problem still occurs, please change the battery.
43	Total power from the battery cells is too high	Please change the battery.
44	Voltage of the single cell is too high	Please change the battery.
45	Temperature from the battery is too high	Please let the eBike cool down. If problem still occurs, please change the battery.

Continued- 7. HMI / Display Error Code

Bafang HMI Error Code Definitions: Model C221/C231

The display can show the errors of that may occur on your Always Bike. If an error is detected, the error code appears on the display and one of the following error codes will be displayed.

Note: Please read the description of the error code carefully. If you see the error code, restart the system first. If the problem is not resolved, please contact your dealer.

ERROR CODE	Description	Technical Support
46	The temperature of the battery is too low	Please bring the battery to room temperature. If the problem still occurs, please change the battery.
47	SOC of the battery is too high	Please change the battery.
48	SOC of the battery is too low	Please change the battery.
61	Switching detection defect	1. Check the gear shifter is not jammed. 2. Please change the gear shifter.
62	Electronic derailleur cannot release	Please change the derailleur.
71	Electronic lock is jammed	1. Using the BESST tool update the Display to see if it resolves the problem. 2. Change the display if the problem still occurs, please change the electronic lock.
81	Bluetooth module has an error	Using the BESST tool, re-update the software onto the display to see if it resolves the problem. If not, Please change the display.

8. WARRANTY POLICY

MANUFACTURER'S LIMITED LIFETIME WARRANTY on ALWAYS eBIKES & The RIDE RADIANT CARBON

WHO MAY USE THIS WARRANTY?

eBliss Global Inc. dba Always Bikes & The RIDE Bikes, located at 1211 W. 6th Street Unit 600 #533, Austin, TX 78703 ("**we**") extends this limited warranty only to the consumer who originally purchased the product ("**you**"). It does not extend to any subsequent owner or other transferee of the product.

WHAT DOES THIS WARRANTY COVER and FOR WHAT PERIOD OF TIME?

This limited warranty has 5 category segments of coverage. Each segment has its own coverage detail and limitations. **Please refer to each segment** (Frame, Fork, e-Components, Traditional Bicycle Parts, NOT COVERED) **for each Brand-** (Always & The Ride)

Warranty Program Outline- full details in TERMS of LIMITED WARRANTY		
ALWAYS BIKES GENERAL POLICY on MANUFACTURER DEFECTS		
<i>Notes- This policy is only for ALWAYS BIKES Brand</i>		
Frame	LIFETIME-LIMITED	Frame Only
Fork	36 Month- LIMITED	Rigid or Suspension
e-Components	36 Month- LIMITED	Display/HMI, Wiring Harness, Controller, Torque/Cadence/Speed Sensor, Motor
Traditional Bicycle Parts	36 Month- LIMITED	Headset, Stem, Handlebar, Brakes, Gears, Belt, Crank, Pedal, BB, Rim, Spokes, Wheels, Seat, Seat Post
NOT COVERED	Wearable Products	Tires, Tubes, Brake Pads, Brake Bleeds, Cracked Displays

Warranty Program Outline- full details in TERMS of LIMITED WARRANTY		
The RIDE SIGNATURE CARBON GENERAL POLICY on MANUFACTURER DEFECTS		
<i>Notes- This only applies to CARBON FIBER FRAMES</i>		
Frame	12 Month-LIMITED	Frame Only
Fork	12 Month- LIMITED	Rigid or Suspension
e-Components	12 Month- LIMITED	Display/HMI, Wiring Harness, Controller, Torque/Cadence/Speed Sensor, Motor
Traditional Bicycle Parts	12 Month- LIMITED	Headset, Stem, Handlebar, Brakes, Gears, Belt, Crank, Pedal, BB, Rim, Spokes, Wheels, Seat, Seat Post
NOT COVERED	Wearable Products	Tires, Tubes, Brake Pads, Brake Bleeds, Cracked Displays

Continued 8. WARRANTY POLICY

MANUFACTURER'S LIMITED LIFETIME WARRANTY on ALWAYS eBIKES and The RIDE RADIANT CARBON

WHAT IS THE PERIOD OF COVERAGE?

We have **2 policies** so know your bike. If you have questions, please reach out.

ALWAYS BIKES - This limited warranty starts on the date of your purchase and lasts for the duration as **outlined above** during your sole ownership or until the period expires. This is non-transferable. (the "**Warranty Period**"). The Warranty Period is not extended if we repair or replace the product and does not cover any labor rates unless approved in advance. We cannot guarantee exact item replacement but will ensure it will be compatible and of equal or greater value than the defective product. We may change the terms of this limited warranty at our discretion, but any changes will not be retroactive.

The RIDE RADIANT CARBON BIKES - This limited warranty starts on the date of your purchase and lasts for the duration as **outlined above** during your sole ownership or until 12months expires. This is non-transferable. (the "**Warranty Period**"). The Warranty Period is not extended if we repair or replace the product and does not cover any labor rates unless approved in advance. We cannot guarantee exact item replacement but will ensure it will be compatible and of equal or greater value than the defective product. We may change the terms of this limited warranty at our discretion, but any changes will not be retroactive.

WHAT DOES THIS WARRANTY NOT COVER?

This limited warranty does not cover any damage due to: (a) transportation; (b) storage; (c) improper use; (d) failure to follow the product instructions or to perform any preventive maintenance; (e) modifications; (f) unauthorized repair; (g) normal wear and tear; or (h) external causes such as accidents, misuse, abuse, neglect, theft or other actions or events beyond our reasonable control.

This bicycle is not intended for trick riding, ramp riding, jumping, aerobatics, aggressive riding, riding on severe terrain, riding in severe climates, racing, riding with heavy loads, riding with more than one person, institutional or industrial use, use with a motor, rental, or any similar activities. Such use may damage the bicycle, can cause serious injury, and in all cases shall void this warranty.

WHAT ARE YOUR REMEDIES UNDER THIS WARRANTY?

In the event of a defect, malfunction, or other failure of the product not caused by any misuse or damage to the product, we will, in our sole discretion, either repair or replace such product (or the defective part) free of charge. We will also pay shipping and handling fees to return the repaired or replacement product to you.

Continued 8. WARRANTY POLICY

MANUFACTURER'S LIMITED LIFETIME WARRANTY on ALWAYS BIKES and The RIDE RADIANT CARBON

HOW DO YOU OBTAIN WARRANTY SERVICE?

To obtain a warranty service, email our Customer Service Department during the Warranty Period to obtain a Return Authorization-Defective Authorization ("**RA-D#**") number. No warranty service will be provided without an RA-D #. [eMail-support@alwaysbikes.com](mailto:email-support@alwaysbikes.com) or file a claim online- **ALWAYSBIKES.com/Support**.

WHAT CAN YOU DO IN CASE OF A DISPUTE WITH US?

If any dispute, controversy or claim arises out of or relates to (i) the product, other e-bike components, or the assembled e-bike, or (ii) this warranty or the breach, termination, or invalidity hereof (each, a "**Dispute**") and if such Dispute cannot be settled through negotiation with us, you agree first to try in good faith to settle the Dispute by mediation administered by the American Arbitration Association under its Commercial Mediation Procedures before resorting to arbitration. If such mediation proves unsuccessful, any such Dispute shall be settled by arbitration administered by the American Arbitration Association under its Commercial Arbitration Rules, and judgment on the award rendered by the arbitrator(s) may be entered in any court having jurisdiction. You agree that these procedures are the exclusive mechanisms for resolving any Dispute with us that may arise from time to time.

Key Technical Features

A. Wheel Safety

WARNING! Riding with an improperly secured wheel can allow the wheel to wobble or fall off the eBike. This could cause serious injury or death.

- Please contact Always Bikes at support@alwaysbikes.com or 888-341-6450 or ask your dealership for support on how to safely use, install or remove your wheel
- Know and understand the correct technique for safely securing your wheel in place.
- BEFORE EACH RIDE- check your wheels prior to each ride to ensure they are secure and safe.

NOTE: Most eBike front forks have a safety/secondary retention device tabs on the fork dropouts. These secondary tabs are NOT designed to secure your wheel but will help support disengagement.

WARNING! Do not remove or disable the safety/secondary retention device. This is a critical safety element and serves as a back-up for a critical adjustment. Safety/secondary retention device is NOT a substitute for correctly securing your wheel. Failure to properly secure the wheel can allow the wheel to wobble or fall off the eBike. This could cause serious injury or death.

GUIDE HOW to USE SAFELY

B. Cam Action or Quick Release Skewer

There are 2 main systems in the marketplace. Both systems have similar looking parts

- Adjusting Cap
- Cam Level
- Skewer that is attached to lever
- 2 Springs that are cylinder shape
- Plate next to cam
 - Option 2 has a cup shape
- Set up Skewer with
 - Lever
 - Plate
 - 1 Spring
 - Slide thru Hub
 - 1 Spring
 - Adjusting Cap
- You are now set for CLAMPING and SECURING the WHEEL in the fork
- Hand adjust your Adjusting Cap
- Move lever from Open to Closed POSITION
 - This is tension based
 - You want to ensure this takes force to close COMPLETELY
 - You might have to make adjustments with NUT to ensure proper closure
 - ALWAYS make sure lever is positioned upward

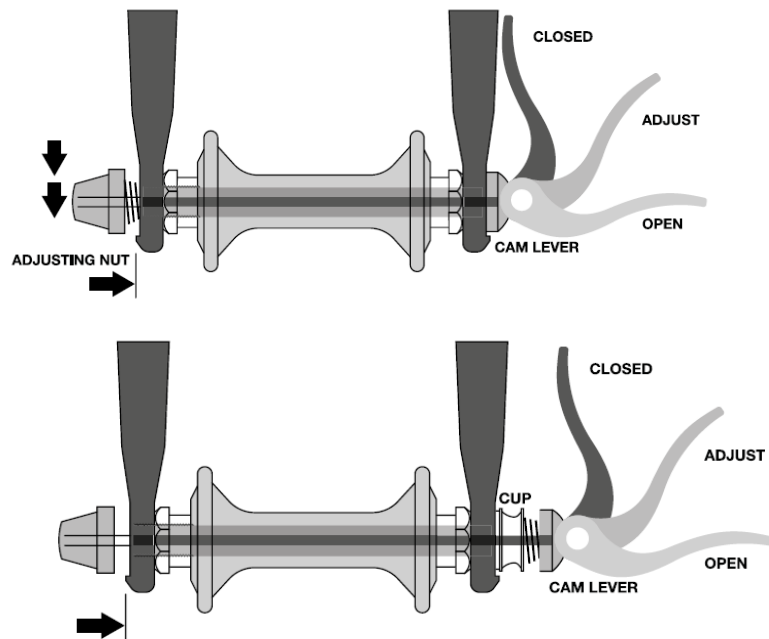

Key Technical Features

C. Thru Axel Bolt / Skewer

This is a bolt that uses an Allen wrench to secure your front wheel.

- You must relieve pressure on the front wheel. We suggest the following method
 - Have a friend lift the front of the bike
 - Turn bike upside down (be careful of balance, weight and the display)
 - Use a work stand to support and lift bike
- Align wheel in front fork
- Press axel into hub
- Use Allen wrench to tighten and secure
- Ensure axel is secure, tight, and safe

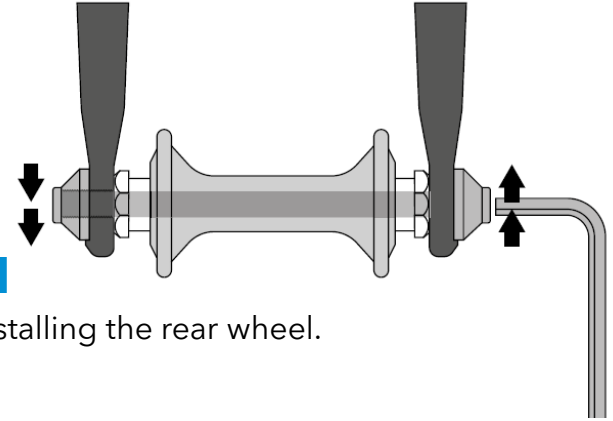

D. Rear Wheel Installation and Removal

There are completely elements to note when removing and installing the rear wheel.

- Axel Nut Position
- Slotted Torque Washers
- Belt System
- Disc Brake

NOTE: PLEASE follow these steps

- Position bike so you have good access to rear wheel and have relieved any weight on back of bike.
 - Have a friend lift the rear of the bike
 - Turn bike upside down (be careful of balance, weight and the display)
 - Use a work stand to support and lift bike
- Disengage Motor Cable
 - Remove Zip tie on motor cable going to rear wheel
- Loosen both sides of the Axel Nuts (you do not need to completely remove them)
 - Note position on Slotted Torque Washers
 - CAREFULLY disengage the Belt System
 - Lift Rear Wheel out of dropouts SLOWLY and slide belt off of axel.
 - Show Caution and Awareness to the disc brake rotor and alignment
 - DO NOT SQUEEZE Brake lever with wheel removed. This could cause brake issues or failure
- Installing Rear Wheel
 - Align wheel in Rear Triangle- Prior to placing in drop out
 - Slide Belt over Axel. Ensure the belt is aligned. You do not need to engage on rear cog yet
 - Align Disc Rotor
 - Align Slotted Torque Washer
 - Place in Drop Out
 - Align Belt on gears and ensure it is on properly
 - Secure and Tighten Axel Nuts
 - Check Disc brake and ensure working correctly
 - Reconnect Motor Cable and secure. Ensure working
 - Ensure wheel is centered, secure, and tightened

Key Technical Features

E. eBike Fit and Adjustments

WARNING! It is important to ensure your bike fits you properly. We provide 2 different frame styles to help provide a safe and enjoyable ride performance

Frame Style and Size

1. TOP TUBE- this is a traditional bicycle frame look where you will need to throw your leg over the tube. With this style, please ensure
 - You have stand over clearance
 - You are comfortable with weight and handling of bike
2. STEP THRU- this has an open cockpit area to where you can step thru without throwing your leg over a tube.

Saddle / Seat Position

Correct position is key to safety and comfort of your ride. Improper position could cause you to be unstable and lose balance, This could cause serious injury or death.

You have the following adjustments to make

1. Height- You can adjust the height of the saddle significantly. Please note the following
 - The seat post has a MINIMUM insertion indication. MAKE SURE you follow this guide. Failure could cause the component to fail.
 - Adjust the height so that at MINIMUM you have a slight bend in your knee while your foot is on the pedal at the lowest location. This is a traditional bicycle ride position
 - NOTE: many eBike riders ride with a lower seat position to help ease stopping position and ease of getting on and off. It is important for you to feel comfortable in you position for all aspects of your ride. Try different heights and position to find what is most comfortable and safe for you! Do not raise to high to where you will rock side to side while riding. This is NOT SAFE
2. Saddle Position- Fore/Aft- You can slide your seat closer to the front of the bike or push it back to increase your reach. This adjustment should be done when you are looking for a safer and more comfortable reach to the handlebar
 - To make this adjustment loosen the bolt on the seat post that is connecting the seat- Adjust and Secure and Tighten. Check seat to ensure it is secure
3. Saddle Angle / Tilt- You can adjust the angle of the saddle by doing the same adjustment noted in Saddle Position. It is suggested to have your saddle nose level to the ground. This is generally the most comfortable position. But this is a rider preference adjustment. Find your best and most comfortable position. Ensure your saddle is always secure and tight

NOTE: It is important for you to feel comfortable in your position for all aspects of your ride. Try different heights and position to find what is most comfortable and safe for you!

Key Technical Features

F. Torque Settings

The below spec is for Always Bikes		issued 10/01/2024	
All figures in the table below are available in Newton Meters (NM), Inch-Pound (IN-LB), and Foot-Pounds (FT-LBS). Note that some companies do not specify torque for certain components or parts thus we offer a range. Contact the manufacturer for the most up to date specifications.			
Headset - Handlebar SPEC			
Component	Torque Spec Newton Meters (NM)	Torque Spec Inch-Pound (IN-LB)	Torque Spec @ Foot-Pounds (FT-LBS)
Stem- Binder Bolt(s) to steer tube- (Threadless)	6.215	55	4.58
Stem-Binder Bolt (s) to Handlebar	10	88.5	7.375
Stem- Binder Bolt Threadless Compression Bolt	3.955	35	2.92
Stem- Binder Bolt to Internal Steer Tube/Fork (QUILL STYLE)	19.66-29.38	174-260	14.5-21.66
Grips with Locking Mechanism			0
Shift Lever to Handlebar (Clamp)	5.98-7.91	53-70	4.42-5.83
Brake lever-MTB type	5.98-7.91	53-70	4.42-5.83
Bell to Handlebar (clamp)	1.92	17	1.416666667
Monitor to Handlebar (clamp)	1.02	9	0.75
Throttle to Handlebar (clamp)	1.92	17	1.416666667

Seat - Seat Post SPEC			
Component	Torque Spec Newton Meters (NM)	Torque Spec Inch-Pound (IN-LB)	Torque Spec @ Foot-Pounds (FT-LBS)
Seat Rail Binder to Seat Post	19.66-39.21	174-347	14.5-28.92
Seat Post Binder (IF BOLT)	Seat post requires only minimal tightening to not slide downward. Avoid over tightening	Seat post requires only minimal tightening to not slide downward. Avoid over tightening	Seat post requires only minimal tightening to not slide downward. Avoid over tightening
Quick release Seat Post	Measured torque not typically used. Common industry practice is resistance at lever halfway through swing from open to fully closed.	Measured torque not typically used. Common industry practice is resistance at lever halfway through swing from open to fully closed.	Measured torque not typically used. Common industry practice is resistance at lever halfway through swing from open to fully closed.

Crankset - Bottom Bracket - Pedal SPEC			
Component	Torque Spec Newton Meters (NM)	Torque Spec Inch-Pound (IN-LB)	Torque Spec @ Foot-Pounds (FT-LBS)
Pedal into crank	16.95	150	12.5
Crank bolt (including spline- type cranks and square-spindle cranks)	34.46-44.18	305-391	25.42-32.58
Chainring bolt- steel	7.91-10.73	70-95	5.83-7.92
Chainring bolt- aluminum	4.97-9.94	44-88	3.67-7.33

Key Technical Features

F. Torque Settings

The below spec is for Always Bikes		issued 10/01/2024	
All figures in the table below are available in Newton Meters (NM), Inch-Pound (IN-LB), and Foot-Pounds (FT-LBS). Note that some companies do not specify torque for certain components or parts thus we offer a range. Contact the manufacturer for the most up to date specifications.			
Component	Torque Spec Newton Meters (NM)	Torque Spec Inch-Pound (IN-LB)	Torque Spec @ Foot-Pounds (FT-LBS)
Rear derailleur mounting bolt	7.91-9.72	70-86	5.83-7.18
Rear derailleur cable inch bolt	3.96	35	2.916666667
Rear derailleur pulley wheel	3.05-3.84	27-34	2.25-2.83
Front Derailleur clamp mount	4.97-6.78	44-60	3.67-5
Front derailleur cable pinch	4.97-6.78	44-60	3.67-5

Wheel - Hub - Rear Cog SPEC

Component	Torque Spec Newton Meters (NM)	Torque Spec Inch-Pound (IN-LB)	Torque Spec @ Foot-Pounds (FT-LBS)
Quick release at wheel	Measured torque not typically used. Common industry practice is resistance at lever halfway through swing from open to fully closed.	Measured torque not typically used. Common industry practice is resistance at lever halfway through swing from open to fully closed.	Measured torque not typically used. Common industry practice is resistance at lever halfway through swing from open to fully closed.
Wheel axle nuts to frame	22.6-25.42	200-225	16.67-18.75
Cassette sprocket lockring	29.38-49.04	260-434	21.67-36.17
Hub cone locking nut	9.83-24.52	87-217	7.25-18.08
Freehub body	34.46-49.04	305-434	25.42-36.17

Disc Brake System SPEC

Component	Torque Spec Newton Meters (NM)	Torque Spec Inch-Pound (IN-LB)	Torque Spec @ Foot-Pounds (FT-LBS)
Disc rotor to hub	2.04-3.96	18-35	1.5-2.92
Caliper mount	5.99-7.8	53-69	4.42-5.75
Hydraulic hose fittings	4.97-9.94	44-60	3.66-5

E-Bike Component SPEC

Component	Torque Spec Newton Meters (NM)	Torque Spec inch-pound	Torque Spec @ Foot-Pounds (FT-LBS)

Safety Check- Mechanical

It is recommended to do a mechanical safety check prior to every ride. This is a safety and performance recommendation.

WARNING! Correct tightening force on fasteners - nuts, bolts, screws - on your eBike is important. Too little force, and the fastener may not hold securely. Too much force, and the fastener can strip threads, stretch, deform, or break. Either way, incorrect tightening force can result in component failure, which can cause you to lose control and fall.

- Ensure nothing is loose- check all parts, bolts, nuts to confirm properly secure and tight
- Wheels- confirm wheels are aligned, secure and tight. Check Quick Release Skewer, Thru Axle, or Axle Nuts
 - Lift end of bike and spin wheel ensure wheel is true
- Tires- check for abnormal wear, confirm and check bead seat on the rim. Check tire pressure to ensure safe ride
- Brakes- squeeze lever and ensure you have proper performance
 - Lift end of bike and spin wheel and ensure the disc rotor is not rubbing and spins freely- Squeeze brake to ensure stopping power
- Seat and Seat Post- ensure post is secure in frame and does not move. Seat ensure proper position and angle of the seat to allow for proper ride comfort and performance
- Handlebar- ensure all items are properly positioned, secure, and tight

Safety Check- e-Component

It is recommended to do a safety and performance check on all e-components to ensure a safe and enjoyable ride. The following is a suggested guide.

- Charging- it is recommended to charge your eBike after every ride. Note CHARGING SAFETY SECTION
 - Ensure charger is plugged directly into a wall outlet
 - Ensure charger does not overheat
- Battery Review- it is good to periodically remove the battery from the bike and review
 - Do a physical touch and visual review of your battery.
 - Ensure there are no bulges, leaks, discoloration. If any are present DO NOT RIDE and contact ALWAYS BIKES
 - Check the performance by pressing the light button
 - Check prongs on the bike battery cavity to ensure all are aligned & no damage
- Confirm wiring harness is in good visual shape and no pinches, cuts, secured & connected
- Display / HMI- turn on display and ensure it is reading battery charge

Safety Check-

An eBike and its parts do not last forever. It is important to do regular inspection of your ebike and all of its parts. Check for wear, discoloration, cracks, etc. If any of these issues are noticed seek professional review or reach out to Always Bikes.

Maintenance, Safety & Service Guide

Safety Check List

EBikes travel at higher speeds, on average, compared to pedal-only bikes, they are also heavier in comparison; because of this, users must take care to never abuse their eBike.

- Make sure to inspect all items on your eBike, wheels, brakes, and ensure all items are always secure and tight.
- Avoid traveling over terrain which can damage the tires or wheels.
- Ensure tire pressure is adequate to avoid pinch flats and damage from low pressure.
- Check tire pressure regularly

Check the Wheels

- If the wheel does not spin straight fix or replace
- If the wheel wobbles side to side or up and down when spinning fix or replace
- If the wheel becomes un-true or spokes loosen. Do not attempt to true or tighten unless you have adequate knowledge, tools and experience fix or replace

Low tire pressure may result in loss of control, and overinflated tires may burst. Failure to always maintain the air pressure rating indicated on pneumatic tires may result in tire and/or wheel failure. Do not overinflate or underinflate tires. Inflate your tires from a regulated air source with an available pressure gauge. Inflating your tires from an unregulated air source could overinflate them, resulting in a burst tire.

Wheels and Tires

- Bike tires should be checked before every ride and maintained as needed to keep your bike safe and fun to ride.

If you do not have the experience, skill, and tools to complete all steps in the checklist, we recommend consulting a local, certified, and reputable bike mechanic for help with these procedures

Maintenance, Safety & Service Guide

Safety Check List

Check the brakes.

Test the brakes for proper function.

- Sit on the bike in a clear and open area with the bike ON.
- Engage the front brake (on the left side of the handlebar).
- Lightly apply the throttle. The bike should not move since the brake is applied and the e-brake cutoff switch is engaged.
- Release the throttle.
- Release the brake.
- Test that the bike and throttle will operate with the brake not engaged.
- Release the throttle.
- Apply the rear brake (on the right side of the handlebar) and repeat steps to test the other brake.

If the brakes do not cut off the power, immediately discontinue use of the bike and contact Rad Power Bikes as soon as possible. If any other items in the above checklist appear to be out of order, immediately discontinue use of the bike until the item is serviced.

Brakes Safety Check

- Ensure neither the front or rear brake levers touch the handlebar when you fully squeeze the brake levers.
- Check brake pads for wear and ensure they are not over-worn.
- Ensure brake pads are correctly positioned in relation to the brake rotor.
- Ensure brake control cables are correctly adjusted and display no obvious wear.
- Ensure brake control levers are lubricated and tightly secured to the handlebars.
- Test that brake, motor cutoff functions, are functioning properly when the brake levers are squeezed.

If you do not have the experience, skill, and tools to complete all steps in the checklist, we recommend consulting a local, certified, and reputable bike mechanic for help with these procedures

Avoid Moisture and Salt

Keep your electrical components dry.

Never immerse or submerge the bike or any components in water or liquid. Doing so can damage the electrical system.

Rain is designed to flow off electrical components from top to bottom, so be sure to keep the bike upright when the bike is wet and while it is drying.

WARNING: DAMAGE TO YOUR EBIKE'S ELECTRICAL SYSTEM CAUSED IN ANY MANNER, INCLUDING WATER INTRUSION, CAN LEAD TO BATTERY FAILURE, ELECTRICAL SYSTEM MALFUNCTION, OR ELECTRICAL FIRE AND CONSEQUENT PROPERTY DAMAGE, INJURY, OR DEATH. Follow all recommendations to minimize chance of water damage.

Maintenance, Safety & Service Guide

Perform Regular Maintenance

Keep up with maintenance

- When any bike is exposed to wet conditions, it will need a more frequent maintenance schedule to prevent rust and corrosion and to ensure all systems work safely.

Clean your bike as needed

- To clean your bike, wipe the frame with a damp cloth.
- If needed, apply a mild, non-corrosive detergent mixture to the damp cloth and wipe the frame.
- Dry by wiping with a clean, dry cloth.
- Never use the spray from a hose or a high-pressure washer on your ebike.

Pre-Ride Safety Checklist

Before every ride, we recommend running through the following checklist to ensure all components of the bike are in good working condition.

Check that all components are secure.

- Ensure all fasteners are secure & torqued to recommended torque specifications provided in the Owner's Manual. Look for anything that appears unusual, damaged, or missing.
- Ensure your battery is fully charged and locked to the bike.
- Ensure all externally visible electrical connectors are securely and fully connected.

Check tire pressure.

- Check the tire pressure with an air pressure gauge and inspect tires for damage.
- Make sure tires are properly inflated to the tire pressure recommended in the Owner's Manual.

Check the seat.

- Ensure the seat is at a safe and comfortable height so the rider can safely mount, pedal, stop, and dismount the bike safely.

If you do not have the experience, skill, and tools to complete all steps in the checklist, we recommend consulting a local, certified, and reputable bike mechanic for help with these procedures

Maintenance, Safety & Service Guide

Perform Regular Maintenance

Keep up with maintenance

- When any bike is exposed to wet conditions, it will need a more frequent maintenance schedule to prevent rust and corrosion and to ensure all systems work safely.

Clean your bike as needed

- To clean your bike, wipe the frame with a damp cloth.
- If needed, apply a mild, non-corrosive detergent mixture to the damp cloth and wipe the frame.
- Dry by wiping with a clean, dry cloth.
- Never use the spray from a hose or a high-pressure washer on your ebike.

Post-Ride Safety Checklist

It is suggested to review, inspect and make any adjustments or replacements after each ride.. This review will help keep your eBike in good operating conditions.

Check that all components are secure.

- Ensure all fasteners are secure & torqued to recommended torque specifications provided in the Owner's Manual. Look for anything that appears unusual, damaged, or missing.
- Ensure your battery is fully charged and locked to the bike.
- Ensure all externally visible electrical connectors are securely and fully connected.

Check Wheels and Tire Pressure- see guide

Check Brakes- see guide

Charge Battery so it is ready for your Next Ride!

If you do not have the experience, skill, and tools to complete all steps in the checklist, we recommend consulting a local, certified, and reputable bike mechanic for help with these procedures

Maintenance, Safety & Service Guide

The following is a suggested PRE / POST or BOTH Ride Checklist

		Pre-Ride or Post Ride
Battery Charge	Check for battery charge Charge Battery per charging instructions	BOTH POST
Wheels		
Alignment/Trueness	Check to ensure wheels spin freely and true Check Quick Release, Thru Axel, or Axel Nuts to ensure they are tight and secure	BOTH
Secure Tire Pressure	Check tire pressure to ensure properly inflated	BOTH PRE
Tire Wear	Inspect for any wear, abnormal wear, and seating of tire in rim bead	BOTH
Brakes		
Performance	Review brake lever to rotor to ensure no oil leakage Front/Rear Spin wheel and check for braking power	BOTH BOTH
Rotor Inspection		
Front/Rear	Spin wheels and inspect rotor to ensure no rubbing or bend in the rotor	BOTH
Brake Pads	Check for wear and replace if needed	BOTH POST
Drive Train		
Belt Inspection	Inspect to ensure belt is in proper working condition. Lift rear wheel and spin crank to ensure working properly	BOTH
Crank Inspection	Inspect to ensure crank and chain ring are in good working condition. Check bolts to ensure tight and secure	BOTH
Pedal	Inspect to ensure pedals are in good working condition. Check to ensure tight and secure	BOTH
Bolts-		
Handlebar area	Inspect and ensure all items are tight and secure. Brake Levers, Throttle, HMI/Display, Grips, Stem Face Bolts, Stem Steer Tube Bolts, Steer Tube Compression Bolt	PRE
Seat and Post area	Inspect and ensure saddle is secure and seat post clamp is tight and secure. Ensure seat post is inserted in the bike beyond minimum insertion level on the seat post	PRE
Rest of Bike	Review, Inspect all other bolts, nuts, accessories mounts on your bike to ensure tight and secure	PRE
Bike Inspection		
Overall Visual	Do a visual and touch inspection of your eBike to ensure no damage or issues. Suggested to wipe your eBike down with a towel after each ride	POST POST

Maintenance, Safety & Service Guide

Maintenance Schedule

Important - The checklists below may be labeled by a specific time scale however these time scales are directed at the daily rider. If you're just a weekend warrior or intermittent, casual rider then your eBike is going to need these tune-ups less frequently.

If you're a daily rider, then doing some further research and purchasing the tools and equipment necessary to complete these lists may be to your long-term benefit; plus, you get to become much more knowledgeable on the full cycling experience.

Please only do the work you are comfortable with. We will work to offer the needed support but at any point please seek your local professional for help and support!

WEEKLY E-Bike Checklist

This is a safety and general maintenance checklist

1. Wipe down the bike completely. Please note your bike has internal gears and is belt driven so the dirt/grease should be nonexistent or minimal at best. **DO NOT USE CHAIN LUBE.** It is recommended to use a disposable towel. Be Careful with moving parts and the gears.
2. It is recommended to check all bolts and areas that could be tightened. This would include the wheels (Quick Release Mechanism or Bolts), Crank Bolts, Handlebar and Stem area etc.
3. Inspect Brake function and brake pads

MONTHLY E-Bike Checklist

This is a more in-depth inspection and maintenance that would generally be referred to as a basic tune-up

1. Do a full visual inspection of your bike and make note of any unusual markings, cracks, or something that does not seem to be correct. If found seek additional professional support.
 - a. Pro Tip - wipe the bike down as you are doing the visual inspection.
2. Gears and Chain-. Wipe down the bike completely. Please note your bike has internal gears and is belt driven so the dirt/grease should be nonexistent or minimal at best. **DO NOT USE CHAIN LUBE.** It is recommended to use a disposable towel. Be Careful with moving parts and the gears.
3. Check all functions of brakes and gear shifting. You will likely notice something from your last ride, and it is recommended to fix/adjust immediately. If something is noted as not in proper adjustment or alignment fix/adjust immediately.

Maintenance, Safety & Service Guide

6 - MONTH/ANNYUAL E-Bike MAINTENANCE CHECKLIST

This is a more in-depth inspection and maintenance that would generally be referred to as a COMPLETE or FULL TUNE-UP.

NOTE: if components need significant adjustment or replacement costs should reflect the service needed and provided.

1. Do a full visual inspection of your bike and make note of any unusual markings, cracks, or something that does not seem to be correct. If found seek additional professional support.
 - a. Pro Tip - wipe the bike down as you are doing the visual inspection.
2. Gears and Chain-. Wipe down the bike completely. Please note your bike has internal gears and is belt driven so the dirt/grease should be nonexistent or minimal at best. DO NOT USE CHAIN LUBE. It is recommended to use a disposable towel. Be Careful with moving parts and the gears.
3. Adjust and inspect brakes- This is best reviewed when the bike is in a work stand and you can freely spin the wheels. Inspect and view brake pads are in good functioning order. Spin wheel and squeeze lever to insure good solid engagement. Now do other side. If the brakes do not stop quickly and completely check for cable tension and adjust as needed. Also make sure the wheel is true/straight.
4. Wheels- check to ensure quick release and or bolts are properly assembled and secure. Spin wheel to ensure the wheel is true and no damage to tires, rims, or spokes. If damaged or out of alignment, then please seek professional assistance.
5. Check all bearings areas- Hubs, Headset, Bottom Bracket to insure all items are properly adjusted- Moves freely without binding but is not loose or rocking. If either situation presents, please see professional assistance.
6. Safety Check on all bolts- Know your torque setting and check all bolts to insure they are secure and safe.
7. E-Bike Components- Check to insure all items are working properly. Check connection as well as engagement of battery and all connections. Ensure all features of display is also working correctly.

Safety Gear- Additional

eBiking is fun and an adventure but does have risk and potential injury. Please familiarize yourself with your bike, your surroundings, and your capabilities. Know your limits and always feel safe while riding. Wear a helmet, we recommend riders to wear the safety gear that makes you feel safe while riding. This can mean knee and/or elbow pads, reflective vest, lights, and other safety gear.

- If riding at night or low visibility conditions, wear reflective clothing and ensure you have reflectors, headlight and taillight installed on your e-bike.
- Be cautious on wet or raining environment and or surfaces

A FINAL WORD

Ebike riding should be fun and safe. Much of this maintenance is manageable by you, but if you are ever uneasy or unsure, please reach out to your dealership, Always Bikes or seek professional help and support. We want you to be riding safely for a long time to come- ENJOY the RIDE!

9. What's in the BOX

ANYTHING

1. Bike
 - a. Key are zip tied on brake lever
2. Small Parts Box
 - a. Manual
 - b. Charger
 - c. Pedals
 - d. Open Box Wrench
 - e. Allen Wrench



ANYWHERE

1. Bike
 - a. Key are zip tied on brake lever
2. Small Parts Box
 - a. Manual
 - b. Charger
 - c. Pedals
 - d. Front QR Skewer
 - e. Open Box Wrench
 - f. Allen Wrench



OUTA'HERE

1. Bike
 - a. Key are zip tied on brake lever
2. Small Parts Box
 - a. Manual
 - b. Charger
 - c. Pedals
 - d. Open Box Wrench
 - e. Allen Wrench